

**SA 07.2-UW – SA 16.2-UW/SAR 07.2-UW – SAR 16.2-UW
SAV 07.2-UW – SAV 16.2-UW/SARV 07.2-UW – SARV 16.2-UW**

Dimensions Multi-turn actuators with 3-phase AC motor for continuous underwater use

with AUMA plug/socket connector

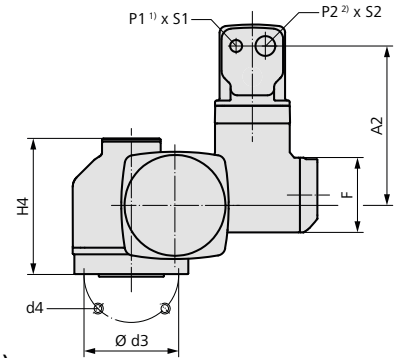
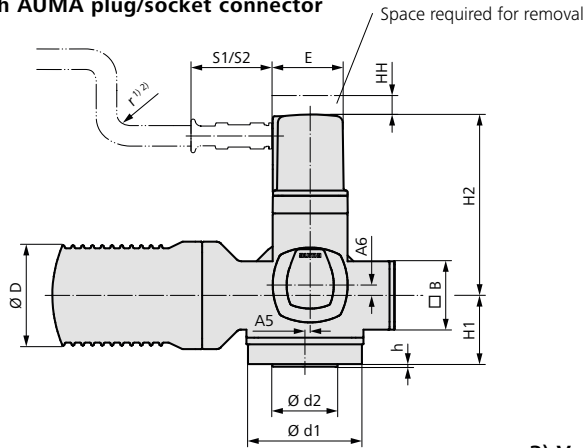

3) Version with handwheel (Option)

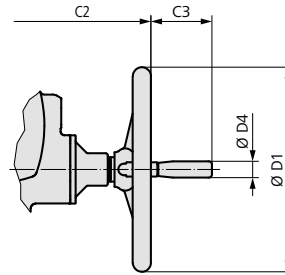
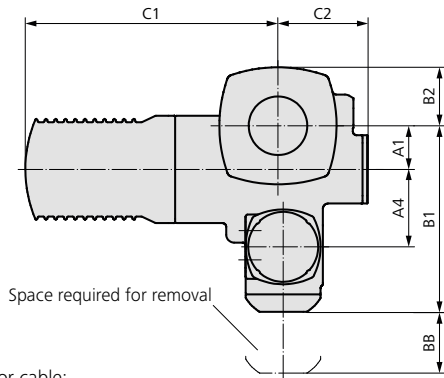

1) Motor cable:

Outer diameter approx. 12.1 mm, minimum bending radius r, fixed installation: 90 mm

2) Hybrid cable with control cables and CAN cables:

Outer diameter approx. 17.2 mm, minimum bending radius r, fixed installation: 105 mm

**Output drives according to EN ISO 5210, DIN 3210
For dimensions see overleaf**

Dimensions	SA 07.2		SA 07.6		SA 10.2	SA14.2	SA 14.6	SA 16.2
EN ISO 5210	F07	F10	F07	F10	F10	F14	F14	F16
A1	40		40		50	67	67	80
A2	229		229		229	245	245	249
A4	103		103		103	119	119	123.5
A5	-		-		-	8	8	15
A6	-		-		-	16	16	20
□ B	70		70		70	105	105	105
B1	238		238		248	286	286	303
B2	62		62		65	90	90	115
C1	268		268		283	389	389	437
C2	112 (196 ³⁾)		112 (196 ³⁾)		112 (197 ³⁾)	138 (254 ³⁾)	138 (256 ³⁾)	156 (276 ³⁾)
C3	63		63		63	94	94	94
Ø D	104		104		124	155	155	192
Ø D1	160		160		200	315	400	500
Ø D4	20		20		20	25	25	25
E	115		115		115	115	115	115
F	115		115		115	115	115	115
H1	96	100	96	100	101	106	106	122
H2	262		262		262	278	278	282
H4	176	180	176	180	188	209	209	244
P1 1)	M20 x 1.5		M20 x 1.5		M20 x 1.5	M20 x 1.5	M20 x 1.5	M20 x 1.5
P2 2)	M32 x 1.5		M32 x 1.5		M32 x 1.5	M32 x 1.5	M32 x 1.5	M32 x 1.5
S1	71		71		71	71	71	71
S2	98		98		98	98	98	98
BB min.	180		180		180	180	180	180
HH min.	30		30		30	30	30	30
Ø d1	90	125	90	125	125	175	175	210
Ø d2 f12	55	70	55	70	70	100	100	130
Ø d3	70	102	70	102	102	140	140	165
d4	4 x M8	4 x M10	4 x M8	4 x M10	4 x M10	4 x M16	4 x M16	4 x M20
h	3		3		3	4	4	5

We reserve the right to alter data according to improvements made. Previous documents become invalid with the issue of this document.

SA 07.2-UW – SA 16.2-UW/SAR 07.2-UW – SAR 16.2-UW
SAV 07.2-UW – SAV 16.2-UW/SARV 07.2-UW – SARV 16.2-UW

Dimensions Output drives according to EN ISO 5210, DIN 3210

Bore with keyway

Type

EN ISO 5210 **B1** $d = d7$ (b/t)
 DIN 3210 **B** $d = d7$ (b/t)
 EN ISO 5210 **B2**¹⁾ $d10 \text{ max.} < d < d7$

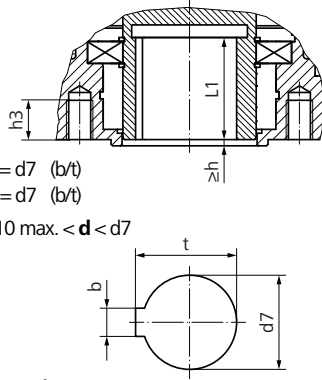

For missing dimensions, refer to actuator

SA.../SAR...	07.2/07.6		10.2	14.2/14.6	16.2
EN ISO 5210	F07	F10	F10	F14	F16
Ø d7 H9	28	42	42	60	80
b JS9	8	12	12	18	22
t	31.3	45.3	45.3	64.4	85.4
Ø d10 max.	20	30	30	45	60
h3	12	15	15	25	30
L1	35	45	45	65	80

Output drive sleeve²⁾

Type

EN ISO 5210 **B3** $d = d10$ (b/t)
 DIN 3210 **E** $d = d10$ (b/t)
 EN ISO 5210 **B4**¹⁾ $d \leq d10 \text{ max.}$

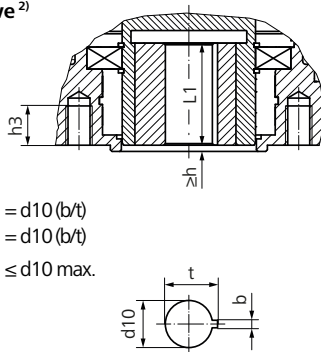

For missing dimensions, refer to actuator

SA.../SAR...	07.2/07.6		10.2	14.2/14.6	16.2
EN ISO 5210	F07	F10	F10	F14	F16
Ø d10 H9	16	20	20	30	40
b JS9	5	6	6	8	12
t	18.3	22.8	22.8	33.3	43.3
Ø d10 max.	20	30	30	45	60
h3	12	15	15	25	30
L1	35	45	45	65	80

Shaft end

Type

EN ISO 5210 **D**
 DIN 3210 **D**

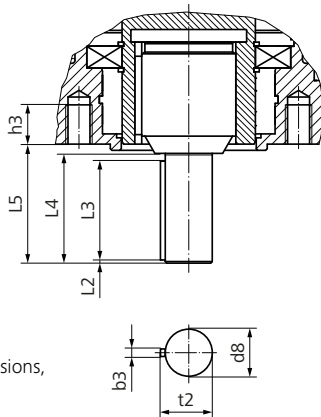

For missing dimensions, refer to actuator

SA.../SAR...	07.2/07.6		10.2	14.2/14.6	16.2
EN ISO 5210	F07	F10	F10	F14	F16
Ø d8 g6	20		20	30	40
b3 h9	6		6	8	12
h3	12	15	15	25	30
L2	1.5		1.5	2	3
L3	45		45	63	80
L4	50		50	70	90
L5	55		55	76	97
t2	22.5		22.5	33	43
Weight kg	0.4		0.7	2	4.3

1) Dimensions b, t depend on Ø dy, refer to DIN 6885-1

2) Weight included in actuator